

# Model 4550

WRAP-AROUND LABELERS



Labeling Systems Inc. (LSI) was founded in 1979 in order to meet the packaging industry's need for heavy duty pressure sensitive labelers required for 24 hour, 7 day a week production demands.

**Rugged Design** - Capable of speeds up to 300 ppm, the fully integrated design incorporates a 7 1/2 foot long conveyor built with 3/8" aluminum side plates, as opposed to sheet metal used on other labelers. A rigid painted steel frame and head mounting provide for a solid, integrated machine base. A large 3/4 hp motor drives the conveyor.

**Flexible Labeling Head** - The Series 3000 Stepper drive head is provided with a 7" wide web and 12" OD roll capacity. The head is a completely enclosed aluminum plate design. A fully supported

label feed drive system with precision ball bearings on the ends of all rotating shafts is standard. Optional Servo drive available.

**Easy to Use** - Controls are simple and require little operator intervention. The unique applicator design eliminates the need for speed matching making for fast changeover and simple set-up.

**Options** - the Model 4550 can be equipped with a thermal transfer, laser, or hot stamp printer for date and lot coding. 16" O.D. roll capacity is available along with a low label and web break detection system and label/product inspection system. PLC controls can also be specified by the customer.



**Labeling Systems Inc.**

32 Spruce Street  
Oakland, NJ 07436  
Tel: (201) 405-0767  
Fax: (201) 405-1179

LabelingSystems.com email: LSI@LabelingSystems.com



# Specifications

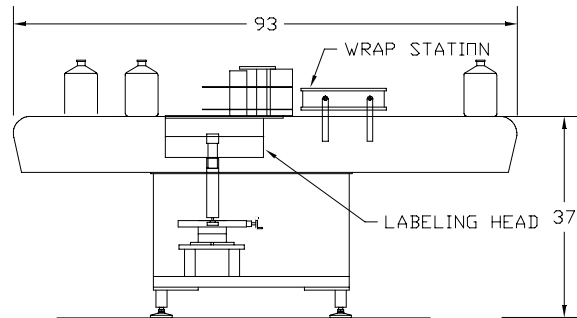
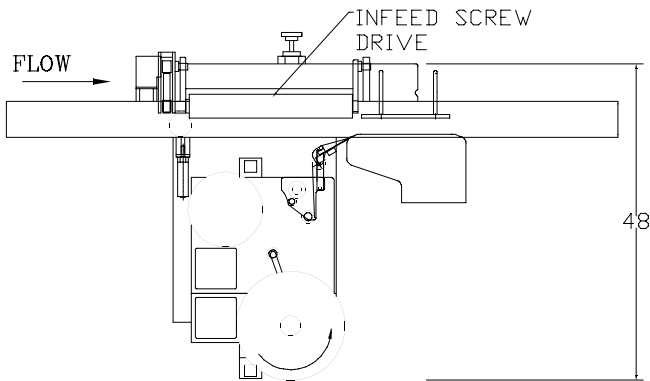

<b>Labeling Head Options</b> Apply Only: Series 3000, 16" unwind optional Stepper Drive, Servo Drive optional	<b>Performance Specifications</b> Speed: up to 300ppm Accuracy: +/- 1/32"
<b>Conveyor</b> Type: 3/8" aluminum plate - delrin chain Std Dimensions: 90"(L) x 4 1/2" (W)	<b>Product Specifications</b> Bottles-straight sides Glass, Plastics, Metals  Diameter*: 1"(min) 5" (max) Height*: 3/4"(min) 14"(max) * consult factory for other
<b>Infeed System Options</b> Type: Single Infeed Screw	<b>Label Specifications</b> Roll Size: 12" O.D. 3" core std Width*: up to 7" Length*: up to 11" Material: paper or film * consult factory for other
<b>Product Control Features</b> Wrap Station: Heavy Duty Wrap Belt, 3" wide std. Optional widths available	<b>Utility Requirements</b> Electrical*: 115v 60 cyl 10amp Some options req. air, 80psi 2cfm * consult factory for other
<b>System Frame / Head Mounting</b> Frame Type: Welded Steel Main Frame, Steel-it paint Stainless Steel Main Frame optional leveling pads std., castors optional Conveyor Height: 34"-36" std. (or as specified) Mounting Type: Z Axis Cradle, fine adjustment mounted to x-y table	<b>Weight</b> 650 lbs. approx



**Labeling Systems Inc.**

32 Spruce Street  
 Oakland, NJ 07436  
 Tel: (201) 405-0767  
 Fax: (201) 405-1179  
 www.labelingsystems.com  
 email: LSI@LabelingSystems.com



**MODEL 1500**