

# Model 1301



The Model 1301 Top Panel Labeler was developed to give accurate and reliable labeling that can be customized to the specific needs of the customer.

Engineered to operate 24 hours per day, 7 days a week with high reliability and low maintenance, the Model 1301 is available with any series LSI labeling head. Print and Apply labeling can be accomplished with the heavy duty Model 2000. The head can be equipped with any OEM print engine from SATO, Zebra, or Datamax. Also available is the Model 300 or Model 3000 apply only heads.

All labeling heads are installed to a heavy duty adjustable head mount assembly. The standard column mount allows for easy adjustment of vertical label placement.

All machine functions are controlled through a central PLC with operator keypad. Optional control packages can be specified by the customer and interface screens customized to the individual requirements of each customer.

The fully engineered and integrated product handling system incorporates a 7 1/2 foot conveyor mounted to a rigid steel to provide a positive drive of the product during the label application. Optional conveyor lengths and widths are available.

The system can be supplied an optional bar code verification system as well as product reject station.



**Labeling Systems Inc.**

32 Spruce Street  
Oakland, NJ 07436  
Tel: (201) 405-0767  
Fax: (201) 405-1179

LabelingSystems.com email: LSI@LabelingSystems.com



# Specifications

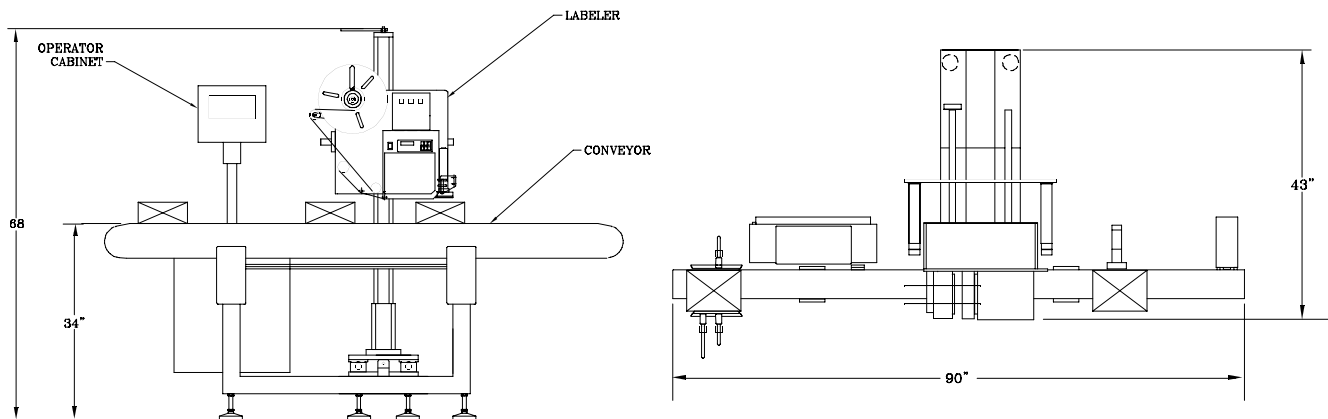

<b>Labeling Head Options</b> Print and Apply: Series 2000 or Series 200 Apply Only: Series 3000 or Series 300		<b>Performance Specifications</b> Speed: up to 60 ppm Accuracy: +/- 1/32	
<b>Machine Controls</b> Type: PLC note: customer can specify type		<b>Product Specifications</b> Boxes, corrugated or chipboard Length*: 4" (min.) 36" (max.) Width*: 4" (min.) 6" (max.) Height*: 4" (min.) 24" (max.) <i>* consult factory for other</i>	
<b>Conveyor</b> Type: delrin chain or belted Std Dimensions: 60" (L) x 4.5" (W) Optional lengths and widths available		<b>Label Specifications</b> Roll Size: 12" O.D. 3" core std Width*: up to 6" Length*: up to 12" Material: paper or film <i>* consult factory for other</i>	
<b>System Options</b> Low Label/Web Break Label Out/Ribbon Out Bar Code Inspection Product Rejection Station		<b>Utility Requirements</b> Electrical*: 115v 60 cyl. 10amp Some options req air, 80psi 2cfm <i>* consult factory for other</i>	
<b>System Frame / Head Mounting</b> Frame Type: Fully integrated aluminum/steel leveling pads std., castors optional Conveyor Height: 24"- 36" std. (or as specified) Mounting Type: gusset column, vertical adj. only		<b>Weight</b> 650 lbs. approx	



## Labeling Systems Inc.

32 Spruce Street  
 Oakland, NJ 07436  
 Tel: (201) 405-0767  
 Fax: (201) 405-1179  
 www.labelingsystems.com  
 email: LSI@LabelingSystems.com

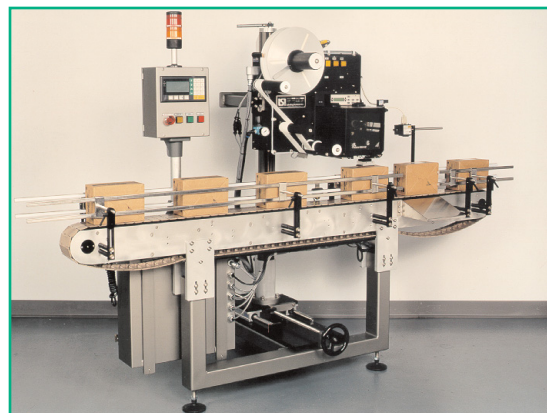

MODEL 1301